

CALCULATION OF AVG. BACK - AREA OF PROJECTED AREA - 53.693 SQM. WIDTH (REAR) OF THE BUILDING - 13.375 MT. AVG. BACK - 53.693 / 13.375 = 4.014 MT.

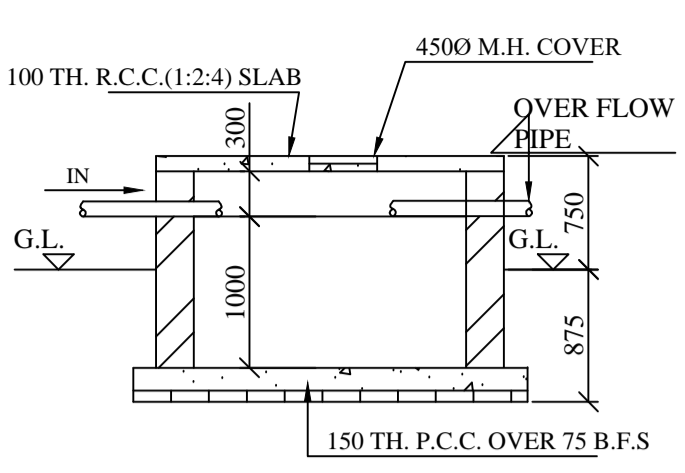

**S.U.G.W. RESERVOIR (800 GALS.)**  
SCALE 1:50

**DOORS & WINDOWS**

MKD.	SIZES	TYPES
D	900X2100	PANELLED
D1	750X2100	PANELLED
D2	1200X2100	PANELLED
W	1200X1200	GLAZED
W1	1500X1200	GLAZED
W2	600X750	GLAZED
W3	800X1200	GLAZED
W4	-	GLAZED

**PART A**  
 1. ASSESSEE NO. - 31-109-13-6633-6  
 2. K.M.C. MUTATION NO. - O/109/27-JUN-22/43947, DATED - 21/09/2022  
 3a. NAME OF OWNERS : SMT. RAKHI DAS & SRI SHREYAJIT DAS  
 b. NAME OF APPLICANT : SRI SANJIB PODDER, ONE OF THE DIRECTOR OF M/S KASAK ABASAN PRIVATE LIMITED, C.A. OF SMT. RAKHI DAS & SRI SHREYAJIT DAS  
 4. B.L.&L.R.O. MUTATION NO. - MUT/165/BLRO/ATM/KASBA/2005, DT. 28.04.2005 (CASE NO. - 4624/05)  
 MUT/165/BLRO/ATM/KASBA/2005, DT. 28.04.2005 (CASE NO. - 4625/05)  
 5. CONVERSION CASE NO. - 46/07, DT. 30.05.2007 SALI TO BASTU 47/07, DT. 30.05.2007 SALI TO BASTU  
 6. DETAILS OF BOUNDARY DECL. :- BOOK NO. - I, VOL. NO. - 1606-2022, PAGES 177133 - 177143, BEING- 160605900, A.D.S.R., SEALDAH, W.B., DT. 06.12.2022  
 7. DETAILS OF POWER OF ATTORNEY :- BOOK NO. - I, VOL. NO. - 1606-2022, PAGES 110822 - 110835, BEING- 160603367, A.D.S.R. SEALDAH, W.B., DT. 12.07.2022  
 8. DETAILS OF DEED:- BOOK NO. - I, VOL. NO. - 129, PG. 485 - 493, BEING NO.- 5473, D.S.R. III, ALIPORE, 24P(S), DT. 22.11.2002  
 9. DECLARATION BEFORE 1ST CLASS MAGISTRATE ALIPORE, VIDE NO.- 3219, DATED - 01/03/2023.

**PART B**  
 1 a) AREA OF LAND (AS PER DEED) :- 334.448 Sqm.  
 b) AREA OF LAND (AS PER BOUNDARY DECL.) :- 334.445 Sqm.  
 2. PERMISSIBLE GROUND COVERAGE :- 185.677 SQM. (55.518%)  
 3. PROPOSED GROUND COVERAGE :- 170.122 SQM. (50.867 %)

**4. PROPOSED AREA**

	TOTAL FL. AREA (SQM.)	EXEMPTED AREA			NET FLR. AREA (SQM.)
		STAIR WAY (SQM.)	LIFT WELL (SQM.)	LIFT LOBBY (SQM.)	
GR. FLOOR	168.677	12.757	—	2.531	153.389
1ST. FLOOR	170.122	12.757	2.144	2.531	152.690
2ND. FLOOR	170.122	12.757	2.144	2.531	152.690
3RD. FLOOR	170.122	12.757	2.144	2.531	152.690
4TH. FLOOR	170.122	12.757	2.144	2.531	152.690
TOTAL FL.	849.165	63.785	8.576	12.655	764.149

**5. A) PARKING CALCULATION**

TENAM. SIZE	PROPORTION AREA TO BE ADDED	TENAM. SIZE (ACT.)	TENAM. NO.	PARKING (REQ.)
74.288 SQM.	12.935 SQM.	87.223 SQM.	4 NOS	4 NOS
77.474 SQM.	13.490 SQM.	90.964 SQM.	4 NOS	

5. B) NOS. OF PARKING PROVIDED = 4 NOS  
 6. PERMISSIBLE F.A.R. = 2.00  
 7. PROPOSED F.A.R. = (764.149 - 100) / 334.445 = **1.986**  
 8. ACTUAL PARKING AREA = 127.840 SQM.  
 9. STAIR CASE AREA = 15.268 SQ.M.  
 10. OVER HEAD WATER TANK = 4.650 SQ.M.  
 11. CUP BOARD AREA = 16.100 SQ.M.  
 12. ADDITIONAL AREA OF FEES = 40.917 SQ.M.  
 13. TREE COVER AREA = 2.250 SQ.M.  
 14. AREA OF L.M.R. = 6.432 SQ.M.  
 15. AREA OF L.M.R. STAIR = 3.117 SQ.M.

**NOTES :-**  
 1. ALL DIMENSIONS ARE IN MILLIMETRES UNLESS OTHERWISE SPECIFIED.  
 2. OUTER WALL - 200, PARTITION WALL - 125, 75.  
 3. USED CONCRETE M-15; GRADE OF STEEL - Fe-415.  
 4. DEPTH OF SEPTIC TANK & S.U.G.W.R. DOES NOT EXCEED THE DEPTH OF FOUNDATION.

**DECLARATION OF L.B.S. --**  
 CERTIFIED WITH FULL RESPONSIBILITY THAT THE BUILDING PLAN HAS BEEN DRAWN UP AS PER PROVISION OF KMC BUILDING RULES 2009 AS AMENDED FROM TIME TO TIME & THAT THE SITE CONDITION INCLUDING THE ABUTTING ROAD CONFORMS WITH THE PLAN, WHICH HAS BEEN MEASURED AND VERIFIED BY ME. IT IS A BUILDABLE SITE NOT A TANK OR FILLED UP TANK. THE LAND IS DEMARCATED BY BOUNDARY WALL. THE PLOT IS WITHIN 500 M. FROM C/L OF E. M. BYE-PASS. \* THE CONSTRUCTION OF U.G. WATER RESERVOIR AND SEPTIC TANK WILL BE COMPLETED BEFORE STARTING OF BUILDING FOUNDATION WORK.

SUMAN MUKHOPADHYAY  
 L.B.S. NO. - 1141, CLASS - I  
 NAME OF L.B.S.

**STRUCTURAL DECLARATION**  
 THE STRUCTURAL DESIGN AND DRAWING OF BOTH FOUNDATION AND SUPER STRUCTURE OF THE BUILDING HAS BEEN MADE BY ME CONSIDERING OF ALL POSSIBLE LOADS INCLUDING SEISMIC LOAD AS PER NATIONAL BUILDING CODE OF INDIA AND CERTIFIED THAT IT IS SAFE AND STABLE IN ALL RESPECT. THE SOIL TEST REPORT DONE BY DR. SANTOSH KR. CHAKRABORTY(GTE/16) OF M/S TECHNO SOIL. HAS BEEN CONSIDERED DURING STRUCTURAL CALCULATIONS.

SAKTI BRATA BHATTACHARYYA  
 (E.S.E. NO. - I, CLASS - 116)  
 NAME OF E.S.E.

**CERTIFICATE OF GEO-TECH. ENGINEER**  
 UNDERSIGNED HAS INSPECTED THE SITE AND CARRIED OUT SOIL INVESTIGATION THEREON. IT IS CERTIFIED THAT THE EXISTING SOIL OF THE SITE IS ABLE TO CARRY THE LOAD COMING FROM THE PROPOSED CONSTRUCTION AND THE FOUNDATION SYSTEM PROPOSED HERE IN IS SAFE AND STABLE IN ALL RESPECT FROM GEO-TECHNICAL POINT OF VIEW.

DR. SANTOSH KR. CHAKRABORTY(GTE/16)  
 NAME OF GEO-TECH. ENGINEER

**DECLARATION OF OWNER / S**  
 WE DO HEREBY DECLARE WITH FULL RESPONSIBILITY THAT I SHALL ENGAGE L.B.S. & E.S.E. DURING CONSTRUCTION OF THE BUILDING (AS PER B.S. PLAN). THE PLOT IS FULLY OCCUPIED BY OWNER & THERE IS NO TENANT IN THE PREMISES.  
 # KMC AUTHORITY WILL NOT BE RESPONSIBLE FOR STRUCTURAL STABILITY OF THE BUILDING & ADJOINING STRUCTURES.  
 # IF ANY SUBMITTED DOCUMENTS ARE FOUND TO BE FAKE, THE KMC AUTHORITY WILL BE REVOKE THE SANCTION BUILDING.  
 # THE CONSTRUCTION OF SEMI UNDERGROUND WATER RESERVOIR AND SEPTIC TANK WILL BE UNDERTAKEN UNDER THE GUIDANCE OF E.S.E. / L.B.S. BEFORE STARTING OF BUILDING FOUNDATION WORK.  
 # DURING DEPARTMENTAL INSPECTION THE PLOT WAS IDENTIFIED BY ME US.

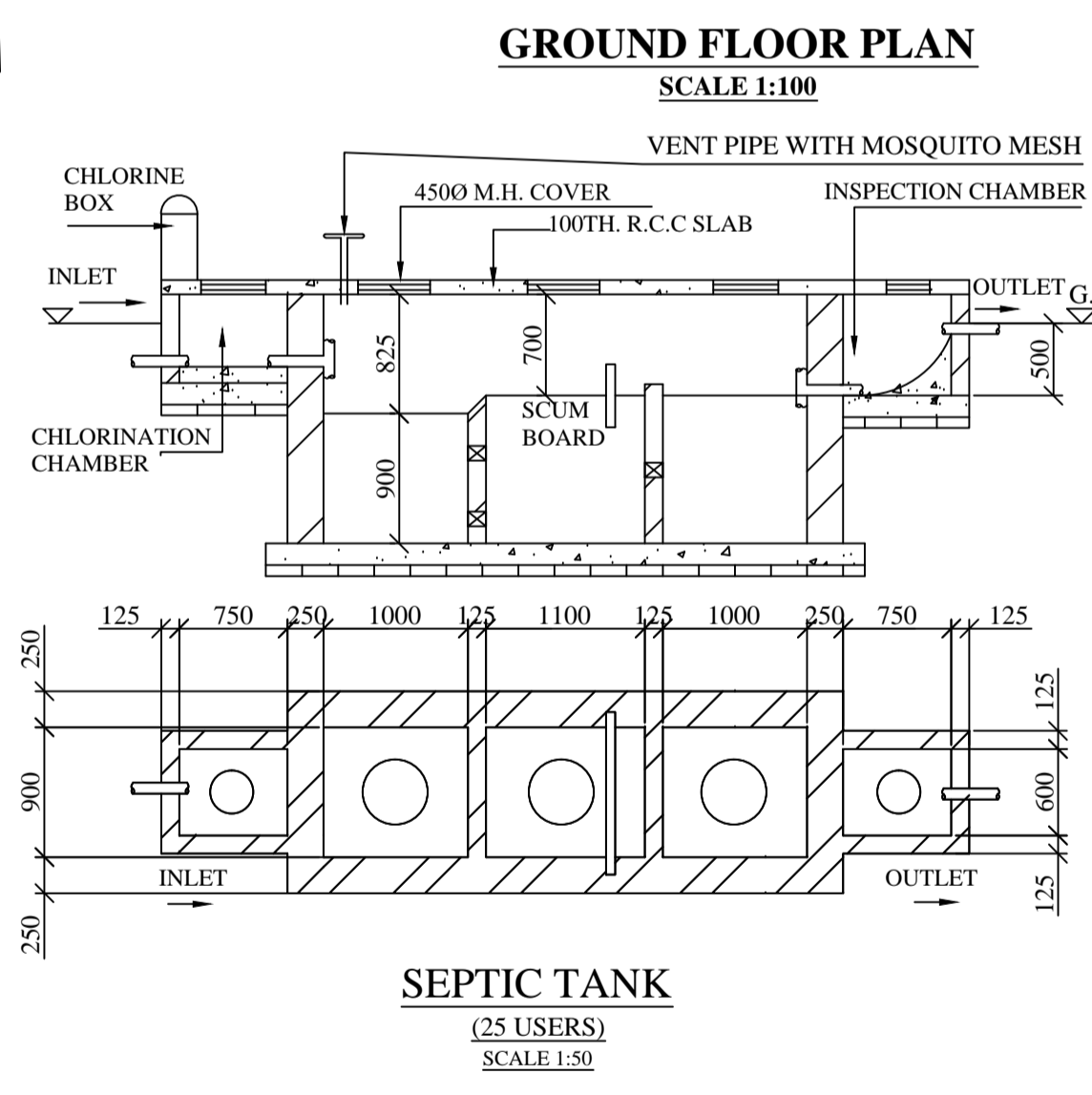

**SEPTIC TANK**  
(25 USERS)  
SCALE 1:50

PERMISSIBLE HEIGHT IN REFERENCE TO CCZM ISSUED BY AAI = 33.00 M.  
 SITE CO-ORDINATES IN WGS 84 AND SITE ELEVATION (AMSL) -

REFERENCE POINTS MARKED IN SITE PLAN OF THE PROPOSAL.	CO-ORDINATES IN WGS 84		SITE ELEVATION (AMSL)
	LATITUDE	LONGITUDE	
(A)	22.48307	88.38857	6.00 M.
(B)	22.48319	88.38845	

THE ABOVE INFORMATION IS TRUE & CORRECT IN ALL RESPECT AND IF AT ANY STAGE, IF IS FOUND OTHERWISE, THEN I SHALL BE LIABLE FOR WHICH KMC AND OTHER APPROPRIATE AUTHORITY RESERVE THE RIGHT TO TAKE APPROPRIATE ACTION AGAINST ME AS PER LAW.

B.P. NO. - 2023120056 DATED- 04-MAY-23  
 VALID UPTO- 03-MAY-28

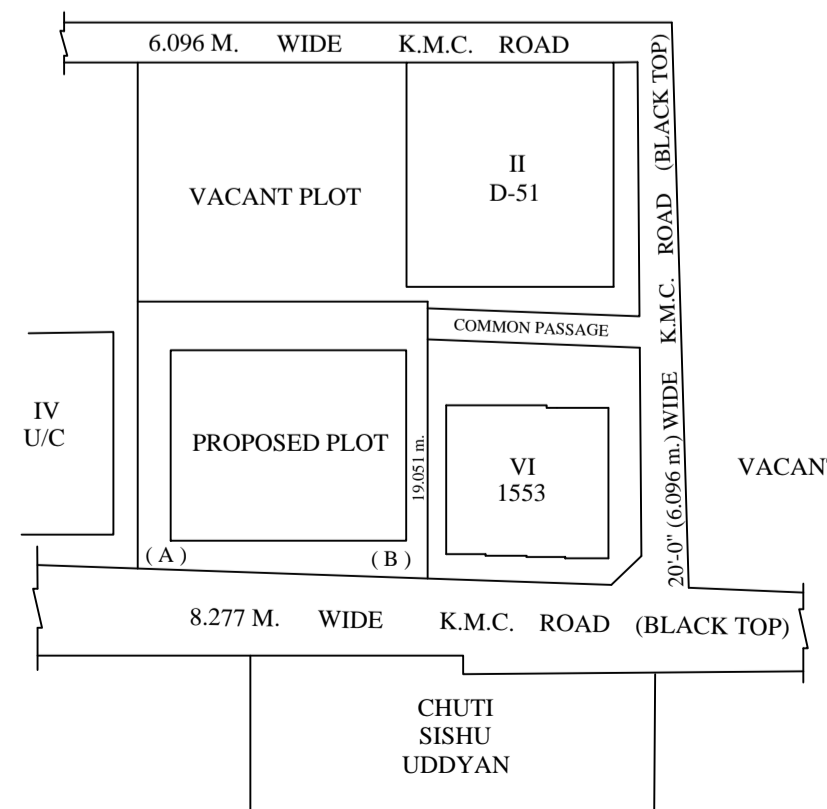

**SITE PLAN**  
SCALE 1:600

DIGITAL SIGN. OF A.E.

DIGITAL SIGN. OF E.E.

SRI SANJIB PODDER, ONE OF THE DIRECTOR OF M/S KASAK ABASAN PRIVATE LIMITED, C.A. OF SMT. RAKHI DAS & SRI SHREYAJIT DAS  
 NAME OF OWNER / S

**PROPOSED G+IV (HEIGHT 15.450 MT.) STORIED RESIDENTIAL BUILDING U/S 393A OF KMC ACT 1980 & COMPLYING B/R 2009, AT PREMISES NO. - 1553, SURVEY PARK, WARD - 109, BR.-XII, K.M.C. (J.U.),MOUZA-RAJAPUR, J.L. NO.-13, KHATIAN NO. - 496, DAG NO. -1002(P) & 1028(P), UNDER P.S. - SURVEY PARK**